



prompt[®]

PACKEASY

bag filling machine

Manual Packaging

VS

Automated Packaging

Lesser and inaccurate speed.	Speed	Higher speed of up to 8-17 bags per min.
Inconsistent weight packaging	Accuracy	Highly accurate weight packaging
High labour cost	Labour	Low labour cost
Low consistency due to dependency on manpower.	Weight Consistency	High consistency in each bag due to auto intelligent close loop feedback system.
Manual reporting of material packaging.	Data Monitoring	System generated auto reporting that can be extracted through USB for analysis.
Low scalability as it is a time-consuming.	Scalability	High scalability with an increase in operations.
Uneven packaging leads to a lower rate of uniformity, and a higher possibility of material wastage.	Uniformity	With quality control and software systems, it has higher uniformity rates and no material wastage.



**Easy
Operation**



**Automated
Control**



**Accurate
Filling**



**CE and OIML
Certified**



IP65

Applications



**Pulses
Granules**



**Spices
Granules**



**Seeds &
Fertilizer**



**Plastic
Granules**

Auto Filler

Specially designed for industrial application with high-speed accuracy in material filling. Single loadcell system for weighing hopper ensures accuracy and reduces maintenance cost

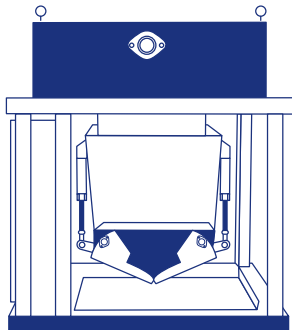
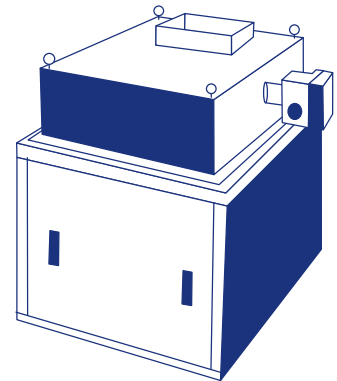

User-friendly Design

The food contacting materials are made of SS304, which is ideal for food packaging

Auto intelligent mechanism

Servo motor for fast, accurate and consistent feeding control

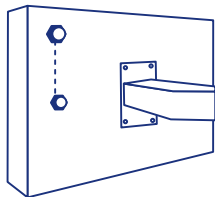
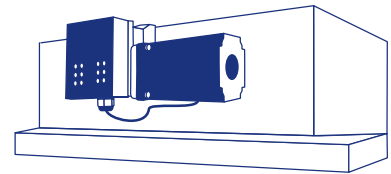

Data Export

Embedded USB for exporting data

User Friendly Display

10-inch touch screen embedded with auto-learning software which displays real-time status, material weight, recipe and other statistics

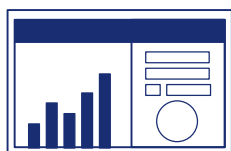
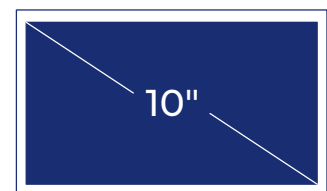

Reports

Detailed analytical reports for decision making



Technical Specifications:

Dimension L X W X H (mm)	(5kg) 2496x1755x825 (25kg) 2996x2492x872 (50kg) 3547x2727x874
Hardware	10 inch Touch Screen, Actuator, F301 Mainboard
Belt Conveyer	Belt conveyer with reverse and forward direction, motorized height adjustment
Data Export	Data export facility through USB
Comunication	RS485, Modbus TCP/IP
Feeding method	Feeding control by servo motor, pneumatic discharging
Material	Food contacting material: SS304, Other: MS
Controller	Touch Screen Bagging Controller
Power	AC 110 ~ 260V, 50/60Hz (Approximate 200VA)
Filling Mode	3 Stage Feeding(Course, Moderate, fine)
Air Supply	6 Bar
Bag type	Open Mouth
Power Phase	3 Phase
Accessories* (Optional)	Double thread - Auto thread cutter/ Heat sealing

Automatic Bag Filling System is built with self optimizing program that accurately controls the material flow & speed.



Available in various models:

	PAB 5K	PAB 25K	PAB 50K	
Weighing Range	1-5 kg	5-25 kg	10-50 kg	
Accuracy	±5 g	±10 g	±20 g	
Speed	17 bags/Min	14 bags/Min	8 bags/Min	
Volume	11Ltr	55Ltr	86Ltr	

Dimensions:

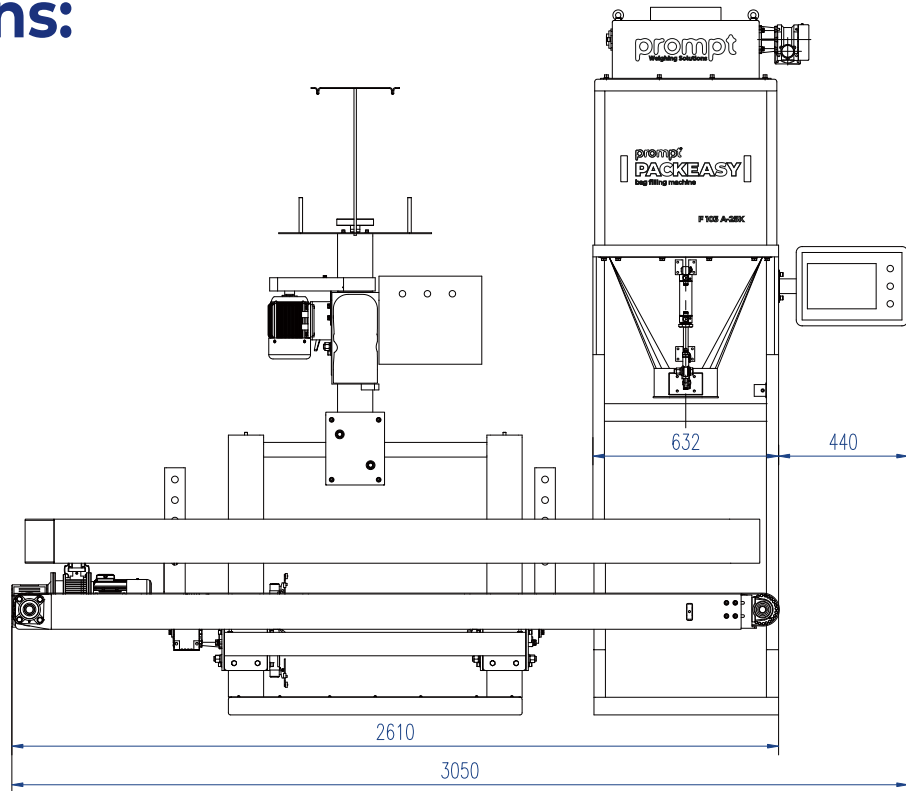

Why choose Prompt?



Three Decades of Legacy

30+ years of experience in the weighing industry



Prompt's Client Base

Over 300+ clients in India



Top-Notch Technology

Exclusive partner of General Measure



Customized Solutions

Customized solutions based on the client's requirements



Prompt's Service Network

Prompt's world-class service spans across 28 states & 270+ districts including the remote area of the country



24 x 7 Assistance

Online assistance 24 hours a day, seven days a week

Prompt Equipments Pvt. Ltd.

7th Floor, Shaligram Corporates, C. J. Road, Iskon - Ambli Road, Ahmedabad, Gujarat – 380058

www.promptscale.com | sales@promptscale.com

Phone: 9712980342 | follow us on    

Scan the QR Code to know more:

